

Fuji USER MANUAL



www.fujitools.com

PIPE BEVELLING MACHINE (PORTABLE TYPE)

MODELS : FBM-16-1,-1S & FBM-24-1,-1S



Full Set
FBM-16-1

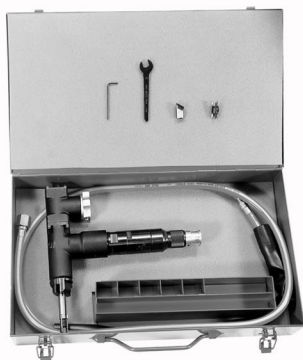

Full Set
FBM-24-1



Standard Accessories

■ FBM-16-1, -1S

AC No.	Description	Qty
IH-8	Inlet Hose	1
EH-50A	Exhaust Hose	1
F-103-1	10mm Open-End Wrench	1
F-702	2.5mm Hex. Pin Wrench	1
BIT-016E01	Bit Toll (External Surface Beveling)	1
CASE-16	Steel Case	1

■ FBM-24-1, -1S

AC No.	Description	Qty
IH-8	Inlet Hose	1
EH-50A	Exhaust Hose	1
F-103-1	10mm Open-End Wrench	1
F-703	3mm Hex. Pin Wrench	1
BIT-024E01	Bit Toll (External Surface Beveling)	1
BIT-024F01	Bit Toll (Flat Surface Beveling)	1
CASE-16	Steel Case	1
S-120016-01	Chuck Ass'y (Spare)	1

SPECIFICATIONS

Model	Capacity (Pipe inside Dia.)		Stall Torque	Rotational Frequency	Feed Length		Side to Center		Overall Length		Mass		Max. Air Consumption	Air Inlet Thread Size	Air Hose Size	
	mm	in			N·m	min ⁻¹	mm	in	mm	in	mm	in			kg	lb
FBM-16-1(-1S)	12 ~ 16	15/32 ~ 5/8	24.5	290	20	51/64	19.0	3/4	261	10 9/16	2.6	5.7	0.4	Rc 1/4	8	5/16
FBM-24-1(-1S)	14 ~ 24	35/64 ~ 15/16	34.3	180	30	1 3/16	27.5	1 5/64	278	10 15/16	2.9	6.4	0.4	Rc 1/4	8	5/16

*(-1S) model: Self Return Handle type.

The performance figures are at 0.63 MPa(6.3bar).



Refer to "The Instructions and Warning for Safety Use" enclosed in each tool box.

Specifications are subjects to change without notice.

ASSEMBLY TOOLS

ABRASIVE TOOLS

DRILLS/TAPPERS

PERCUSSIVE TOOLS

AIR MOTORS

OTHER PRODUCTS

EXPLODED VIEW MODEL :

FBM-16-1, -1S

FBM-16-1, -1S

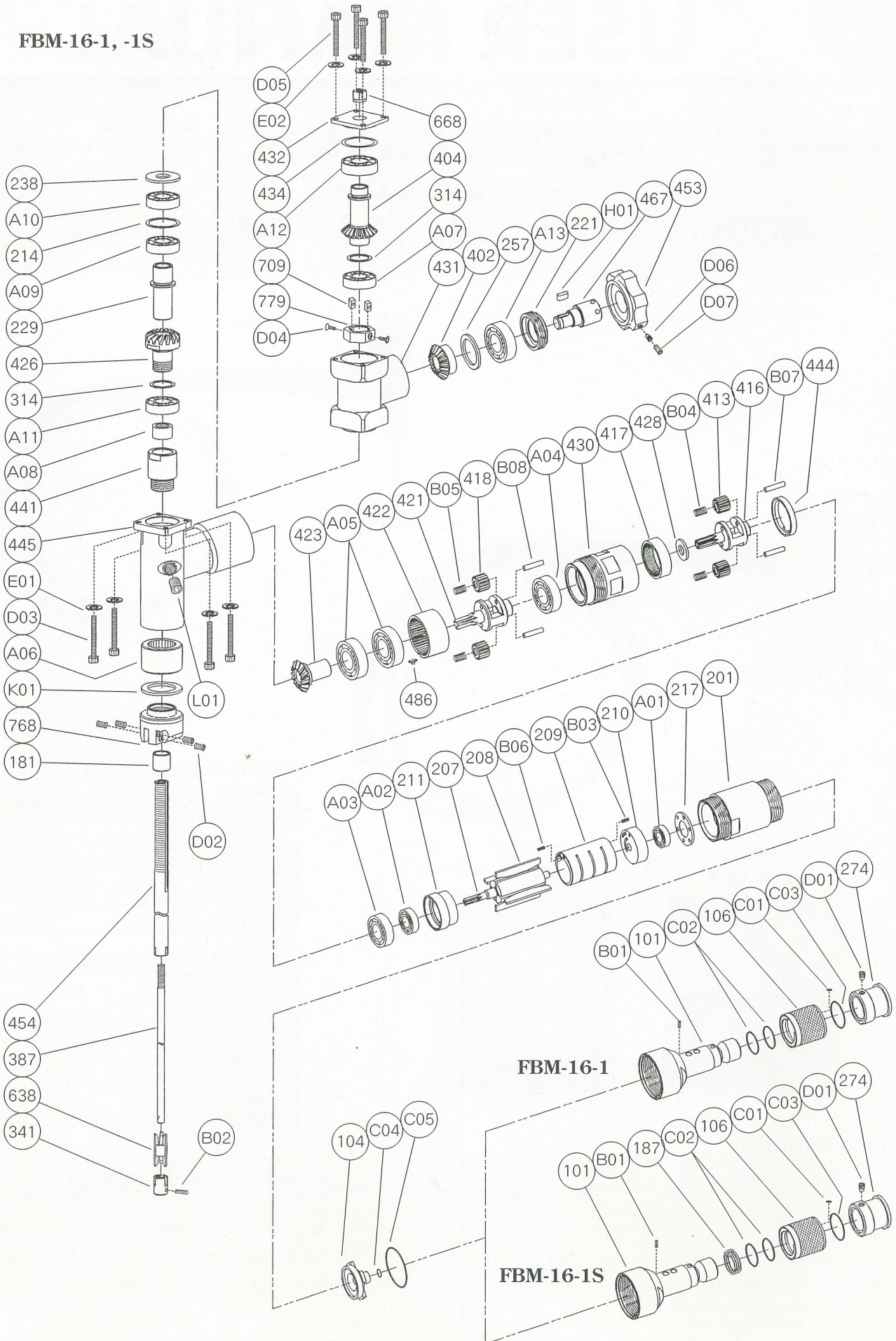

PARTS LIST MODEL :

FBM-16-1, -1S

Index No.	Parts No.	Parts Name	Qt.	Index No.	Parts No.	Parts Name	Qt.
FBM-16-1							
Ass'y No.	S-120001-00	Housing Cover Ass'y		402	S-138402-00	No.1 Gear	1
101	S-120101-00	Housing Cover	1	404	S-138404-01	No.2 Gear	1
106	G-137106-00	Throttle Valve Handle	1	413	D-051413-00	No.1 Planet Gear	2
274	S-120274-00	Exhaust Hose Nipple	1	(B04)	NR-110.5	Needle Roller	30
B01	SP-26	Spring Pin	1	416	S-120416-00	No.1 Planet Gear Frame	1
C01	O-4	"O" Ring	1	417	T-001417-00	No.1 Internal Gear	1
C02	O-P20	"O" Ring	2	418	M-127418-00	No.2 Planet Gear	2
C03	O-1019	"O" Ring	1	(B05)	NR-110.5	Needle Roller	30
D01	SS-58D	Set Screw	1	421	S-120421-00	No.2 Planet Gear Frame	1
FBM-16-1S				422	M-127422-00	No.2 Internal Gear	1
Ass'y No.	S-120001-01	Housing Cover Ass'y		423	S-138423-00	Bevel Pinion	1
101	S-120101-01	Housing Cover	1	426	S-138426-00	Bevel Gear	1
106	S-120106-00	Throttle Valve Handle	1	428	D-026428-00	Bevel Gear Washer	1
187	S-120187-00	Throttle Valve Handle Spring	1	430	S-120430-00	No.1 Gear Case	1
274	S-120274-00	Exhaust Hose Nipple	1	431	S-138431-00	No.2 Gear Case	1
B01	SP-26	Spring Pin	1	432	S-138432-00	Gear Case Cover	1
C01	O-4	"O" Ring	1	434	S-138434-00	Bearing Washer <T=0.2>	1
C02	O-P20	"O" Ring	2	441	S-138441-00	Spindle	1
C03	O-1019	"O" Ring	1	444	S-120444-00	Internal Gear Washer	1
D01	SS-58D	Set Screw	1	445	S-138445-00	Spindle Case	1
FBM-16-1, -1S				453	S-120453-00	Feed Screw Handle	1
Ass'y No.	S-138016-00	Chuck Ass'y		467	S-138467-00	No.1 Gear Spindle	1
341	S-138341-00	Chuck Collar	1	486	D-004486-00	Internal Gear Knock	1
387	S-138387-00	Locking Bolt	1	709	S-120709-00	Clutch Key	2
454	S-138454-00	Feed Screw	1	779	S-138779-00	Locking Clutch Holder	1
638	S-138638-00	Chuck <12-14>	1	A01	BB-626	Ball Bearing	1
638	S-138638-01	Chuck <14-16>	1	A02	BB-608	Ball Bearing	1
668	S-138668-00	Nut	1	A03	BB-EE4	Ball Bearing	1
B02	SP-2.510	Spring Pin	1	A04	BB-6002LLU	Ball Bearing	1
Ass'y No.	S-138018-00	Tool Holder Ass'y		A05	BB-6202	Ball Bearing	2
181	S-138181-00	Bushing 	1	A06	NB-HK2520	Needle Bearing	1
768	S-138768-00	Tool Holder	1	A07	BB-6903	Ball Bearing	1
D02	SS-58	Set Screw	4	A08	NB-K121520ZW	Needle Bearing	1
104	S-120104-00	Bushing	1	A09	BB-51103	Thrust Bearing	1
201	S-138201-00	Housing	1	A10	BB-6903	Ball Bearing	1
207	T-001207-A	Rotor	1	A11	BB-6903	Ball Bearing	1
208	G-013208-00	Rotor Blade	4	A12	BB-7002	Ball Bearing	1
209	G-011209-01	Cylinder	1	A13	BB-6002	Ball Bearing	1
(B03)	SP-26	Spring Pin	1	B06	SP-26	Spring Pin	1
210	S-120210-00	Cylinder Upper Plate	1	B07	NR-419	Needle Roller	2
211	M-062211-00	Cylinder Lower Plate	1	B08	NR-419	Needle Roller	2
214	S-120214-00	Adjusting Washer <T=0.2>	2	C04	O-P7	"O" Ring	1
214	S-120214-01	Adjusting Washer <T=0.3>	1	C05	O-S36	"O" Ring	1
214	S-120214-02	Adjusting Washer <T=0.5>	1	D03	CS-415	Cap Screw	4
217	S-120217-00	Bearing Cover	1	D04	CS-36S	Cap Screw	2
221	S-138221-00	Spindle Bearing Cover	1	D05	CS-412	Cap Screw	4
229	S-138229-00	Bearing Spacer	1	D06	SS-48C	Set Screw	2
238	S-138238-00	Bearing Cover 	1	D07	SS-410	Set Screw	2
257	S-138257-00	Washer	1	E01	SW-4	Spring Washer	4
314	A-006314-00	Wheel Spindle Washer <T=0.2>	1	E02	SW-4	Spring Washer	4
314	A-006314-01	Wheel Spindle Washer <T=0.3>	1	H01	K-4410	Key	1
314	A-006314-02	Wheel Spindle Washer <T=0.5>	1	K01	OS-G25324	Oil Seal	1
				L01	PL-1/8	Plug	1

- Ass'y No. denotes the assembled parts comprising of more than 1 pc. of parts. The related parts are shown in the thick frame.
- #209, 413 and 418 are supplied together with parts shown in ().
- Specify parts number and quantity in ordering.
- * Index No.209 is furnished with 1 pc. B03 and 1 pc. B06.

EXPLODED VIEW MODEL :

FBM-24-1, -1S

FBM-24-1, -1S

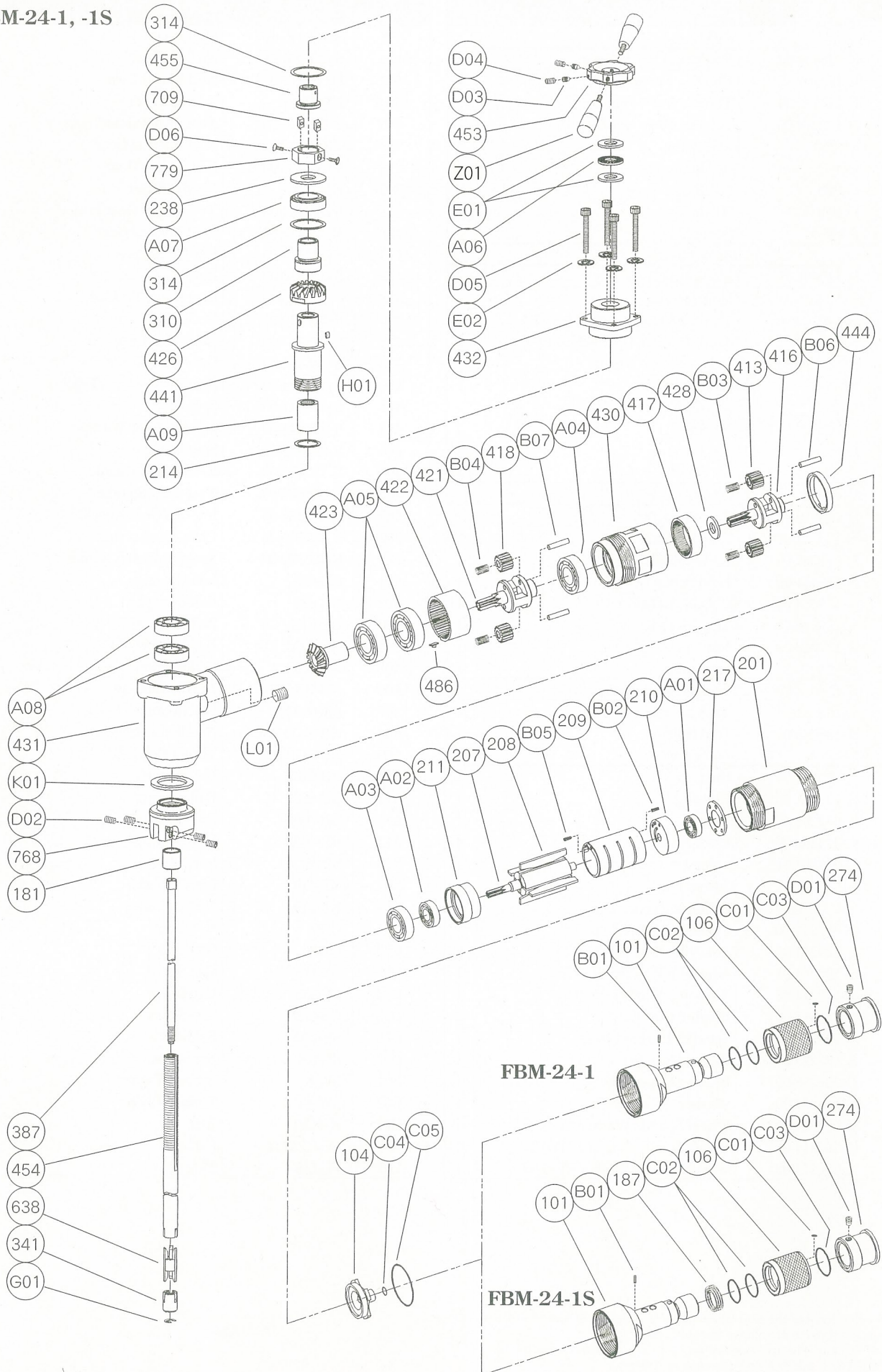

PARTS LIST MODEL : FBM-24-1, -1S

Index No.	Parts No.	Parts Name	Qt.	Index No.	Parts No.	Parts Name	Qt.
FBM-24-1							
Ass'y No.	S-120001-00	Housing Cover Ass'y		310	S-120310-00	Spindle Arbor	1
101	S-120101-00	Housing Cover	1	314	A-109314-00	Wheel Spindle Washer <T=0.5>	1
106	G-137106-00	Throttle Valve Handle	1	314	A-109314-01	Wheel Spindle Washer <T=0.3>	1
274	S-120274-00	Exhaust Hose Nipple	1	314	A-109314-02	Wheel Spindle Washer <T=0.2>	1
B01	SP-26	Spring Pin	1	413	D-051413-00	No.1 Planet Gear	2
C01	O-4	"O" Ring	1	(B03)	NR-110.5	Needle Roller	30
C02	O-P20	"O" Ring	2	416	S-120416-00	No.1 Planet Gear Frame	1
C03	O-1019	"O" Ring	1	417	T-001417-00	No.1 Internal Gear	1
D01	SS-58D	Set Screw	1	418	M-127418-00	No.2 Planet Gear	2
FBM-24-1S				(B04)	NR-110.5	Needle Roller	30
Ass'y No.	S-120001-01	Housing Cover Ass'y		421	S-120421-00	No.2 Planet Gear Frame	1
101	S-120101-01	Housing Cover	1	422	M-127422-00	No.2 Internal Gear	1
106	S-120106-00	Throttle Valve Handle	1	423	S-120423-00	Bevel Pinion	1
187	S-120187-00	Throttle Valve Handle Spring	1	426	S-120426-00	Bevel Gear	1
274	S-120274-00	Exhaust Hose Nipple	1	428	D-026428-00	Bevel Gear Washer	1
B01	SP-26	Spring Pin	1	430	S-120430-00	No.1 Gear Case	1
C01	O-4	"O" Ring	1	431	S-120431-00	No.2 Gear Case	1
C02	O-P20	"O" Ring	2	432	S-120432-00	Gear Case Cover	1
C03	O-1019	"O" Ring	1	441	S-120441-00	Spindle	1
D01	SS-58D	Set Screw	1	444	S-120444-00	Internal Gear Washer	1
FBM-24-1, -1S				453	S-120453-00	Feed Screw Handle	1
Ass'y No.	S-120016-01	Chuck Ass'y		455	S-120455-00	Feed Sleeve	1
341	S-120341-01	Chuck Collar	1	486	D-004486-00	Internal Gear Knock	1
387	S-120387-00	Locking Bolt	1	709	S-120709-00	Clutch Key	2
454	S-120454-01	Feed Screw	1	779	S-120779-00	Locking Clutch Holder	1
638	S-120638-10	Chuck <14-16mm>	1	A01	BB-626	Ball Bearing	1
638	S-120638-11	Chuck <16-18mm>	1	A02	BB-608	Ball Bearing	1
638	S-120638-12	Chuck <18-20mm>	1	A03	BB-EE4	Ball Bearing	1
638	S-120638-13	Chuck <20-22mm>	1	A04	BB-6002LLU	Ball Bearing	1
638	S-120638-13	Chuck <20-22mm>	1	A05	BB-6202	Ball Bearing	2
668	S-120638-14	Chuck <22-24mm>	1	A06	NB-AXK1104	Needle Bearing	1
G01	SR-E5	Snap Ring	1	A07	RB-4T32004X	Roller Bearing	1
Ass'y No.	S-120018-00	Tool Holder Ass'y		A08	BB-6005	Ball Bearing	2
181	S-120181-00	Bushing	1	A09	NB-K141839ZW	Needle Bearing	1
768	S-120768-00	Tool Holder	1	B05	SP-26	Spring Pin	1
D02	SS-610	Set Screw	4	B06	NR-419	Needle Roller	2
104	S-120104-00	Bushing	1	B07	NR-419	Needle Roller	2
201	S-120201-00	Housing	1	C04	O-P7	"O" Ring	1
207	T-001207-A	Rotor	1	C05	O-S36	"O" Ring	1
208	G-013208-00	Rotor Blade	4	D03	SS-48C	Set Screw	2
209	G-011209-01	Cylinder	1	D04	SS-410	Set Screw	2
(B02)	SP-26	Spring Pin	1	D05	CS-514	Cap Screw	4
210	S-120210-00	Cylinder Upper Plate	1	D06	CS-38S	Cap Screw	2
211	M-062211-00	Cylinder Lower Plate	1	E01	TW-AS1104	Thrust Washer	2
214	S-120214-00	Adjusting Washer <T=0.2>	1	E02	SW-5	Spring Washer	4
214	S-120214-01	Adjusting Washer <T=0.3>	1	H01	K-448	Key	1
214	S-120214-02	Adjusting Washer <T=0.5>	1	K01	OS-VB30405	Oil Seal	1
217	S-120217-00	Bearing Cover	1	L01	PL-1/8	Plug	1
238	S-120238-00	Bearing Cover	1	Z01	GR-GTM18xM5	Grip	2

- Ass'y No. denotes the assembled parts comprising of more than 1 pc. of parts.
The related parts are shown in the thick frame.
- #209, 413 and 418 are supplied together with parts shown in ().
- Specify parts number and quantity in ordering.
- * Index No.209 is furnished with 1 pc. B02 and 1 pc. B05.

Chuck and Bit Tools

Chuck Variation

Each Chuck shows the chucking size. Please select the Chuck suitable for the inside diameter of the pipe according to the applicable pipe and chuck list.

Applicable Pipe and Chuck list

■FBM-16-1, -1S

Part No. of Chuck	S-138638-00	S-138638-01	S-138638-03
Inside Dia. of Pipe (mm)	12~14	14~16	18~20

■FBM-24-1, -1S

Part No. of Chuck	S-120638-10	S-120638-11	S-120638-12	S-120638-13	S-120638-14
Inside Dia. of Pipe (mm)	14~16	16~18	18~20	20~22	22~24

How to read figure on Chuck

The figure, engraved on the Chuck, specifies the chucking capacity.

As illustrated alongside, the figure 20-22 denotes 20-22mm chucking capacity and the parts No. of the Chuck is S-120638-13.

Please refer to the illustration and order the required Chuck.

Example

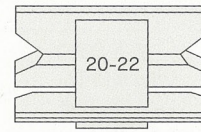

Part No.
S-120638-13

Standard Bit Tools

■FBM-16-1, -1S

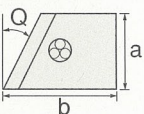
Bit Tool Shape	Part No.	Angle (Q)	Dimensions(mm)		
			a	b	Thickness
For External Surface Beveling 	BIT-016E01	30°	12	25	6

Optional Bit Tools

■FBM-16-1, -1S

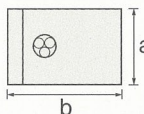
Bit Tool Shape	Part No.	Angle (Q)	Dimensions(mm)		
			a	b	Thickness
For Flat Surface Beveling 	BIT-016F01	—	12	22	6

■FBM-24-1, -1S

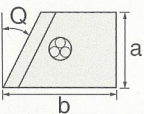
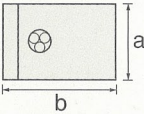
Bit Tool Shape	Part No.	Angle (Q)	Dimensions(mm)		
			a	b	Thickness
For External Surface Beveling 	BIT-024E01	30°	14	32	8
Bit Tool Shape	Part No.	Angle (Q)	Dimensions(mm)		
For Flat Surface Beveling 	BIT-024F01	—	14	25	8

■FBM-24-1, -1S

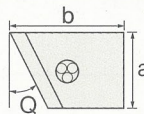
Bit Tool Shape	Part No.	Angle (Q)	Dimensions(mm)		
			a	b	Thickness
For Internal Surface Beveling 	BIT-024B06	30°	14	30	8

※The above standard Bit Tools are included in the standard accessories of the machine.

How to replace Chuck

1. Unscrew the Nut (668) from the Locking Bolt (387) by a spanner (10mm Hex.).

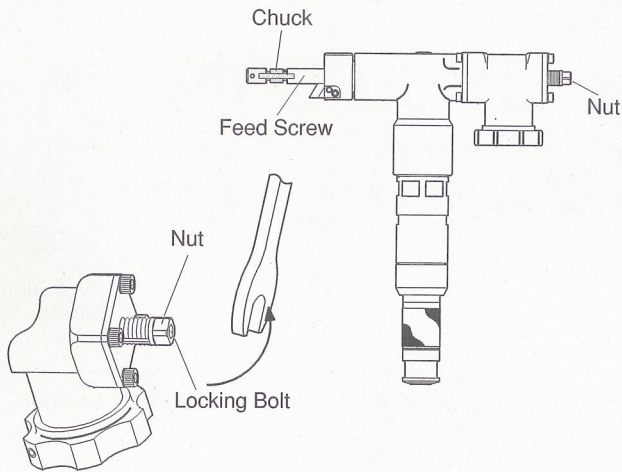

2. Hold the Chuck (638) and pull out the Locking Bolt (387) to the arrow direction.

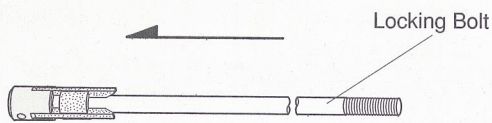

3. Pull out the Chuck (638) from the Locking Bolt (387) to the arrow direction.

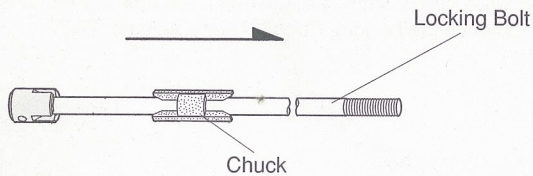

4. Set the Chuck (638) into 3 slots of the Chuck Collar (341). Insert the opposite side of the Chuck (638) into 3 slots of the Feed Screw (454).

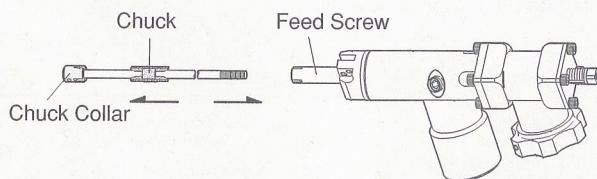

5. Insert the Locking Bolt (387) into the angle head, and fasten the protruded part of the Locking Bolt with the Nut (668).

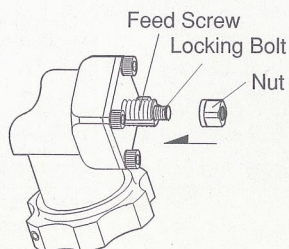

How to make Chuking into Pipe

1. Equip the machine with the Chuck suitable for the pipe inside diameter. Turn the Feed Screw Handle (453) left or right to have the Feed Screw (454) protruded by about 5mm from the angle head.

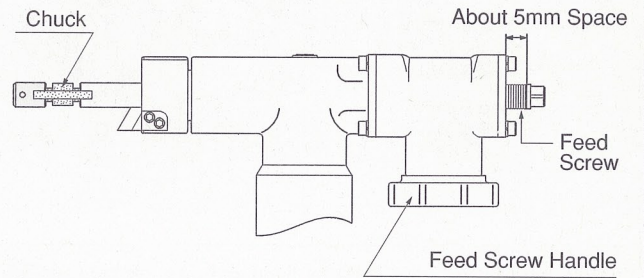

2. Insert the Chuck part into the pipe. The Chuck must be installed in good balance.

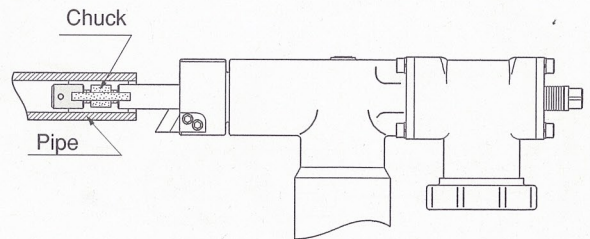

3. Make about 5mm space between the Pipe and the Bit Tool and tighten the Nut (668) by a spanner.

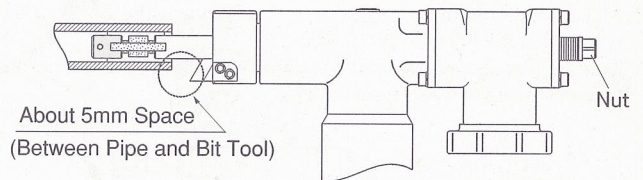

How to separate Chuck part from Pipe

1. Make about 10mm space between the Pipe and the Bit Tool by turning left the Feed Screw Handle (453).
2. Turn left the Nut (668) by a spanner to take out the Chuck part from the Pipe.

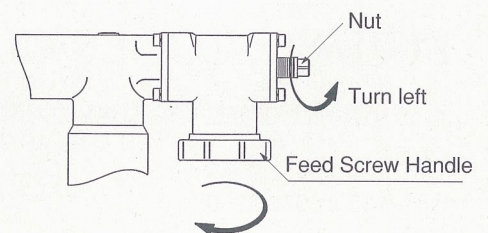

How to replace Chuck

1. Take off the Snap Ring (G01).

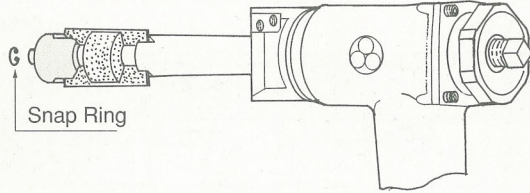

2. Hold the Chuck Collar (341) by hand and turn left by a spanner the square part of the Locking Bolt (387) until the Chuck Collar is separated. The Chuck will be released at the same time.

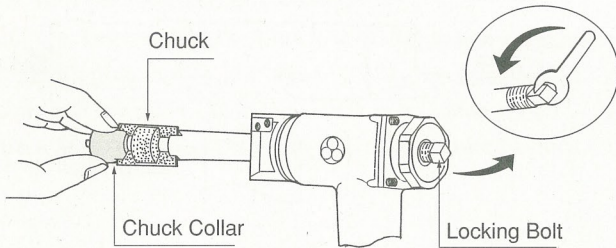

How to separate Chuck part from Pipe

1. Make about 10mm space between the Pipe and the Bit Tool by turning left the Feed Screw Handle (453).
2. Turn left the square part of the Locking Bolt (387) by a spanner to take out the Chuck part from the Pipe.

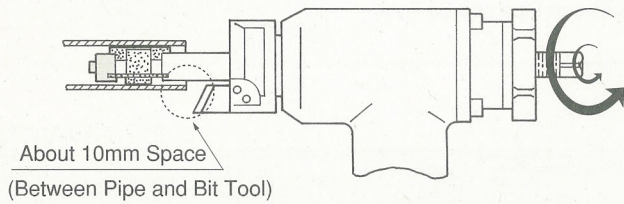

How to make Chucking into Pipe

1. Equip the machine with the Chuck (638) suitable for the pipe inside diameter. Turn the Feed Screw Handle (453) left or right to have the Feed Screw (454) protruded by about 5mm from the angle head.

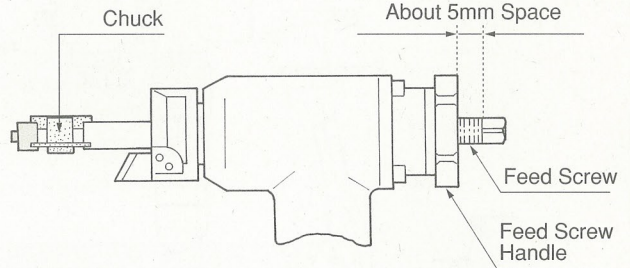

2. Insert the Chuck part into the pipe. The Chuck must be installed in good balance.

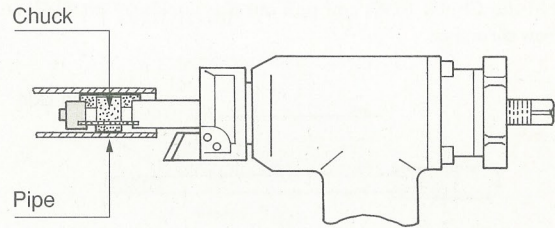

3. Make about 5mm space between the Pipe and the Bit Tool and tighten the Locking Bolt (387) by a spanner.

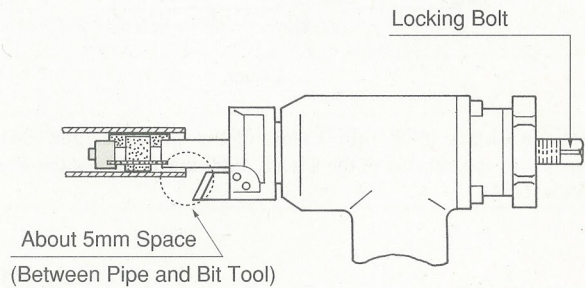

Fuji Industrial Technique Co.,Ltd.

2-1-14, Kamiji, Higashinari-ku, Osaka, 537-0003 Japan

Tel : 81-6-6972-2335

Fax : 81-6-6972-2380